

DESIGN NOTES

Reduce Component Count and Improve Efficiency in SLIC and RF Power Supplies – Design Note 282

Tick Houk

Introduction

Nonisolated power supplies with negative output voltages require op amps and other “glue” circuitry in order to level-shift the feedback voltage to the error amplifier. In applications such as SLIC (subscriber line interface circuit) power supplies, this extra circuitry adds unwanted cost and requires more space on the PC board, with no increase in system performance.

The LTC[®]3704 is a high performance, single-ended current mode DC/DC controller IC that allows the user to directly sense a negative output voltage using the NFB pin. A unity-gain inverting amplifier within the IC, combined with a precision bandgap voltage reference, give users a -1.230V input that can be directly connected to a resistor divider between the negative output voltage and ground. Additional features, such as No R_{SENSE} [™] current mode control, programmable operating frequency (50kHz to 1MHz), synchronization capability and a wide input range (2.5V to 36V) improve efficiency and greatly ease design. The LTC3704 is housed in a small 10-lead MSOP package.

A Dual Output SLIC Supply With Simplified Feedback Using the LTC3704

Figure 1 illustrates a dual output telecom power supply designed for use in subscriber line interface circuits or SLICs. The input to the SLIC power supply is some form of battery (lead-acid or lithium-ion, for example) so that extended talk-time can be provided to POTS (plain old telephone system) phones during an AC line failure (or rolling blackout). The output voltage is typically proportional to the distance the subscriber line runs from the local hub to a house or office, in order to compensate for the impedance of the loop. Multiple output supplies are used to supply groups of users at different distances from the hub.

This SLIC power supply takes advantage of the negative feedback input (NFB) on the LTC3704 and therefore, eliminates the need for an additional op amp. The -24V output is regulated directly and the -72V output is

⚡ LTC and LT are registered trademarks of Linear Technology Corporation. No R_{SENSE} is a trademark of Linear Technology Corporation. VERSA-PAC is a trademark of Coiltronics, Inc.

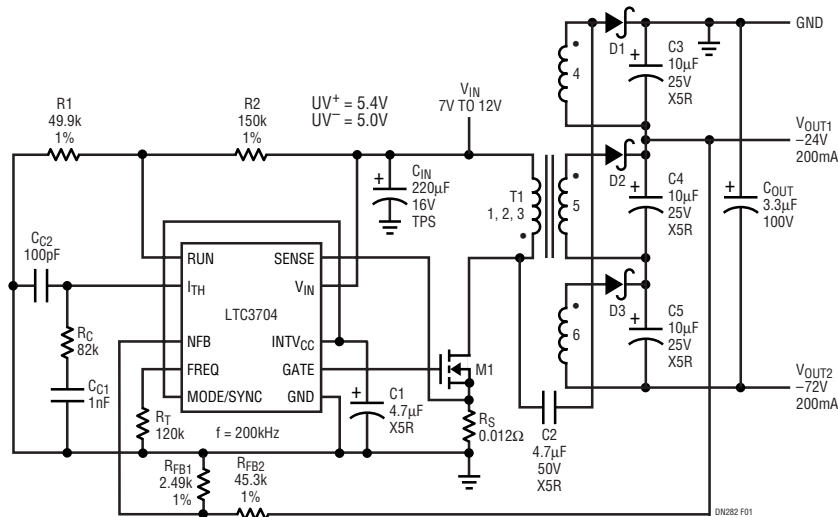

D1 TO D3: INTERNATIONAL RECTIFIER 10BQ060
M1: INTERNATIONAL RECTIFIER IRL2910S
T1: COILTRONICS VP5-0155 (PRIMARY = 3 WINDINGS IN PARALLEL)

Figure 1. Dual Output SLIC Supply with the LTC3704 Simplifies Feedback

obtained by stacking additional windings on the -24V output. The -24V output of this supply uses one secondary winding in a SEPIC-type configuration in order to reduce the input ripple current, whereas the -72V output uses the other two windings in a conventional flyback mode. A standard, 6-winding VERSA-PAC™ transformer (VP5-0155) was used, with 3 windings connected in parallel on the primary in order to satisfy the high current demand (the peak switch current can be almost 4A at an input of 7V). A 5.2V LDO within the LTC3704 provides a regulated supply for the gate driver which is capable of driving very large power MOSFETs (50nC to 100nC).

Improved Battery Protection Using the LTC3704's Programmable Undervoltage Lockout

With most lead-acid or lithium-ion chemistries, deep discharging of the battery cells can severely reduce the life of the battery. As a result, it is important to monitor the battery and turn the converter off before the battery voltage reaches an unsafe level. In Figure 1, the RUN pin on the LTC3704 monitors the battery voltage using resistors R1 and R2 and turns off the power supply when the input supply drops below 5V. A hysteresis level of 8% is provided in order to increase noise immunity (UV^+ is 5.4V).

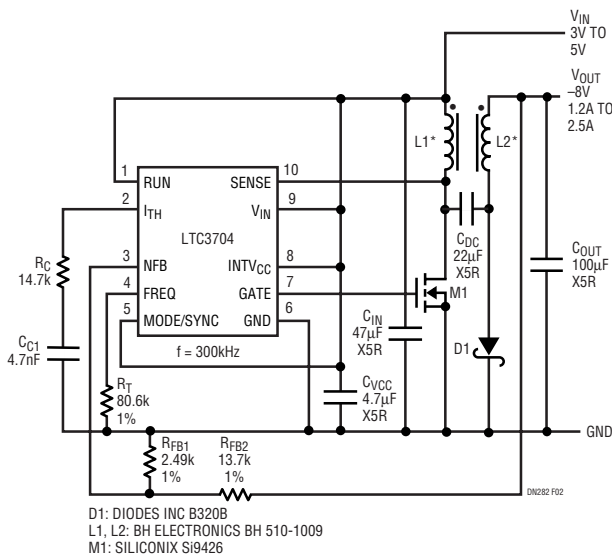

Figure 2. A High Efficiency -8V RF Power Supply

A Current Mode, -8.0V , 1.2A RF Power Supply with No Current Sense Resistor

The design illustrated in Figure 2 takes advantage of LTC's proprietary No R_{SENSE} technology to provide true current mode control without a discrete current sense resistor. The voltage drop across the power MOSFET is sensed during the on-time, thereby providing the control loop with a "lossless" method of measuring the switch current. This technique provides the maximum efficiency possible for a single-ended current mode converter, reduces board space and reduces the overall cost of the power supply in applications where the drain of the power MOSFET is less than 36V (the absolute maximum rating of the SENSE pin). It should be noted that the output voltage and maximum output current of this supply can easily be scaled by the choice of the components around the chip without modifying the basic design.

Figures 3 and 4 illustrate the maximum output current vs input voltage for the supply and the efficiency vs load current at input voltages of 3V and 5V, respectively.

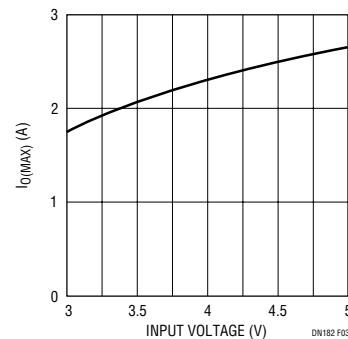

Figure 3. Maximum Output Current vs Input Voltage for the -8V RF Power Supply

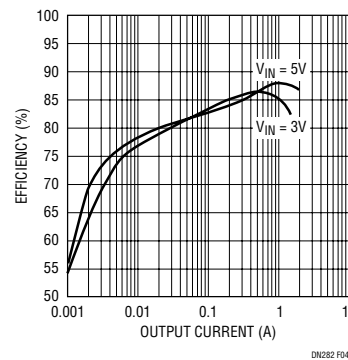

Figure 4. Efficiency vs Output Current for the -8V RF Power Supply

Data Sheet Download

<http://www.linear.com/go/dnLTC3704>

For literature on our Controllers, call **1-800-4-LINEAR**. For applications help, call (408) 432-1900, Ext. 2593